

AP-030 Apartment Compactor

Specifications

Manufacturer's Rated Size	1/3 Cubic Yards
Rated Size	0.30 Cubic Yards
Cycle Time	25 Seconds
Capacity Per Hour	43.2 Cubic Yards / Hour
Clear Top Opening (L x W)	21" x 25"
Ram Face Dimensions (W x H)	18" x 27"
Ram Penetration	6"
Cylinder Bore, Rod & Stroke	4" x 2" x 30"
Operating Pressure	
Normal	1500 PSI
Maximum	2,000 PSI
Ram Force Rating	
Normal	38.79 PSI / 18,850 Lbs
Maximum	51.71 PSI / 25,133 Lbs
Motor (HP)	5 HP
Pump (GPM)	7 GPM
Tank Capacity	10 Gallons
Shipping Weight	1,500 Lbs (approx)

Construction

Frame

Floor Plate	3/8"
Floor Plate Supports	4"-5.4 Lb Channel
Side Plates	1/4"
Ram Hold Down Bars	1" x 1" Bar
Load Binder Hook-Up	5,400 Lbs Capacity

Ram

Face Plate	3/8"
Floor Plate	3/8"
Side Plates	1/4"
Top Plate	1/4"

All Specifications are subject to change without notice.

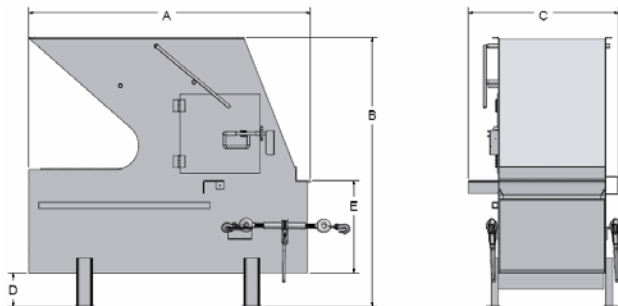

A	B	C	D	E	Capacity
70 3/4"	67 3/4"	37 5/8"	8 1/2"	23 1/4"	1/3 Yard

Installation Requirements

Minimum Recommended Requirements:

- 12'-6" x 15' Room
- (4) 3/4" x 4 3/4" Anchor Bolts

Minimum Clearance Requirements:

- 18" Perimeter
- 6' Door Opening with Fire Doors

Electrical Disconnect Requirements

5 HP Motor

Voltage	Amperage	Fuse
208	30	25
240	30	20
480	30	10

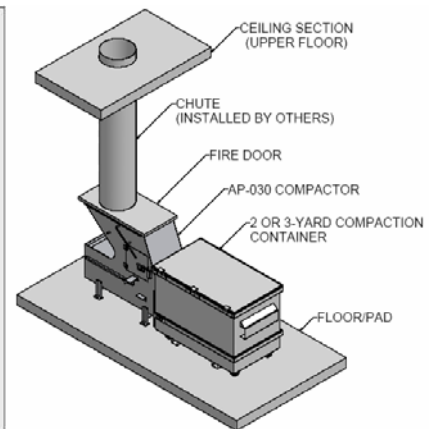
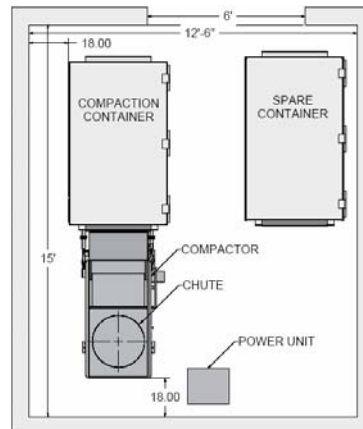
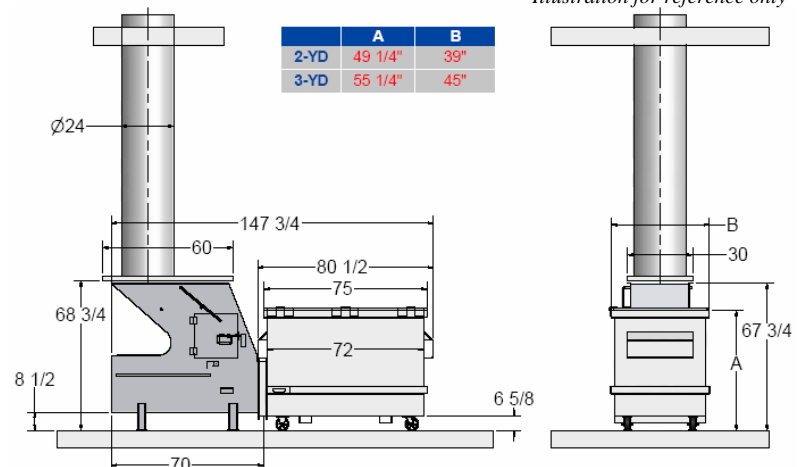

Illustration for reference only



Standard Features

- Photo Eye Start
- Auto-Cycle
- Keyed Start
- 100% Full Indicator Light
- Chute Stop Interlock
- Emergency Stop
- Transformer Included
- 15 Minute Automatic Shutdown
- Programmable Microcontroller

Available Options

- Single Phase Motor
- 80% Full Indicator Light
- Fused Link Fire Safety Chute Door



Distributor

385 Sumpter Road • Belleville • MI 48111-2932 • Phone (734) 699-5561 • Fax (734) 699-0360

P.O. Box 68 • Belleville • MI 48112-0068

On the Web at: <http://www.contractwelding.com>

04/07 REV1