

CP-4HD-2 Stationary Horizontal Compactor

Specifications

Manufacturer's Rated Size	3 Cubic Yards
Rated Size	2.46 Cubic Yards
Cycle Time	51 Seconds
Capacity Per Hour	128.85 Yards
Clear Top Opening (L x W)	66" x 57 1/2"
Ram Face Dimensions (W x H)	59 3/4" x 29 7/8"
Ram Penetration	14"
Cylinder Bore, Rod & Stroke	(Twin) 7" x 4 1/2" x 78"
Operating Pressure	

	Normal	1500 PSI
	Maximum	2000 PSI

Ram Force Rating	Normal	64.68 PSI / 115,454 Lbs
	Maximum	86.24 PSI / 153,938 Lbs

Motor (HP)	20 HP
Pump (GPM)	49 GPM
Tank Capacity	80 Gallons
Shipping Weight	10,000 Lbs (approx)

Construction

Frame	
Floor - AR Plate	1/2" A-36 w/ 1/2" AR 450 Wear Plate
Floor Plate Supports	6" 8.2 Lb Channel
Side Plates	1/2"
Side Reinforcements	6"x3"x1/4" Tube
Breaker Bar	Twin 6" x 3" x 3/8" Tube
Ram Hold Down Bars	1 1/4" x 1 1/4" Bar
Load Binder Hook-Up	165,000 Lbs Capacity

Ram	
Face Plate	1"
Floor - AR Plate	1/2" A-36 w/ 1/2" AR 450 Wear Plate
Side Plates	3/4"
Top Plate	1/2"
Top Plate Reinforcement	4" I-Beam

All Specifications are subject to change without notice.

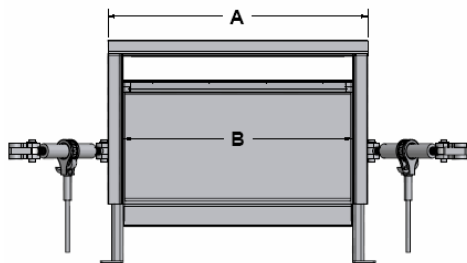
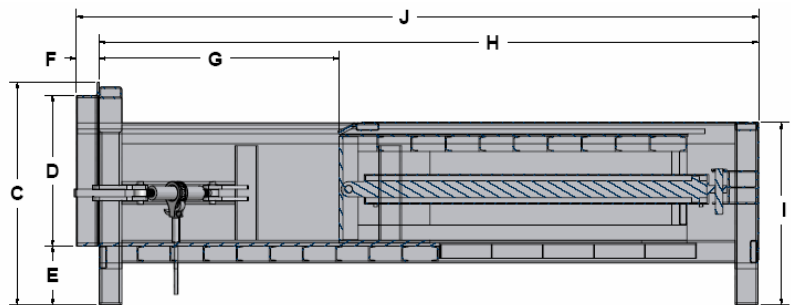

Illustration for reference only



A	B	C	D	E	F	G	H	I	J	Capacity
68"	60"	57 3/4"	38 3/4"	15"	6"	66"	186 3/8"	48 3/16"	192 3/8"	3 Yards

Installation Requirements

Typical Installation Layout

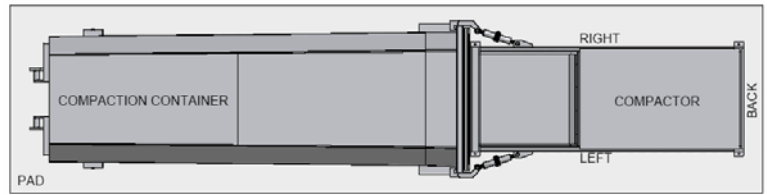

Minimum Recommended Requirements:

- Concrete Pad: 10' x 40' (May be made larger to suit)
4,000 PSI Reinforced, 6" Thick
- (4) 3/4" x 4 3/4" Anchor Bolts

Minimum Clearance Requirements:

- 12" From Back of Compactor to Wall
- 36" From Right & Left of Compactor to Wall

Electrical Disconnect Requirements

20 HP Motor		
Voltage	Amperage	Fuse
208	100	80
240	100	70
480	60	40

Available Options

- Hoppers & Enclosures - Any Configuration
- Through-Wall Chute & Door Framework
- Standard & Full Container Guides
- Pre-Crusher
- Compactor Access Systems
- Custom Clear Top Openings
- Drive-on Ramp
- Cart Dumper
- Wheel Wear Plates
- Oil Heater
- Larger Power Units
*(Faster Cycle Times)

All Compactors can be Customized to Accommodate Any Clear Top Opening



Distributor

385 Sumpter Road • Belleville • MI 48111-2932 • Phone (734) 699-5561 • Fax (734) 699-0360
P.O. Box 68 • Belleville • MI 48112-0068
On the Web at: <http://www.contractwelding.com>

02/07 REV2